

Keep this
manual onboard!



User Manual

For Thruster Models
AC Electric



SLEIPNER AS

P.O. Box 519

N-1612 Fredrikstad

Norway

www.sleipnergroup.com

DOCUMENT ID: 6054

REVISION: 8

DATE: 2021

LANGUAGE: EN

**U
M**

To download your language go to www.sleipnergroup.com

Important User Considerations and Precautions	3
User Manual	
Thruster Operation	4
Proportional Control Panel	5
Maintenance	6 - 7
Troubleshooting	8
Checklist	9
Service and Support	10
Product Spare Parts and Additional Resources	10
Warranty statement	10

Products

SAC320/300-I-2-H - AC Thruster ø300mm 230V
 SAC240/250-C-4-VX01 - AC Thruster ø250mm 400V
 SAC240/250-C-4-V - AC Thruster ø250mm 400V
 SAC520/386-I-4-V - AC Thruster ø386mm 400V
 SAC400/300-C-4-V - AC Thruster ø300mm 400V
 SAC900/513-I-X-X01 - AC Thruster ø513mm 400V
 SAC320/300-I-2-V - AC Thruster ø300mm 230V
 SAC320/300-I-X01 - AC Thruster ø300mm 400V
 SAC700/412-C-X01 - AC Thruster ø412mm 230/400V
 SAC320/300-I-4-H - AC Thruster ø300mm 400V
 SAC450/386-C-4-H - AC Thruster ø386mm 400V
 SAC1100/513-I-4-V - AC Thruster ø513mm 400V
 SAC450/386-C-5-X01 - AC Thruster ø386mm 690V
 SAC700/412-C-4-V - AC Thruster ø412mm 400V
 SAC520/386-C-4-H - AC Thruster ø386mm 400V
 SAC400/300-C-5-X01 - AC Thruster ø300mm 660V
 SAC900/513-I-4-H - AC Thruster ø513mm 400V
 SAC450/386-C-4-V - AC Thruster ø386mm 400V

DECLARATION OF CONFORMITY

MC_0020



Sleipner Motor AS
 P.O. Box 519, Arne Svendsensgt. 6-8
 N-1612 Fredrikstad, Norway

Declare that this product with accompanying standard control systems complies with the essential health and safety requirements according to:

DIRECTIVE 2013/53/EU
 DIRECTIVE 2014/30/EU
 DIRECTIVE 2014/35/EU

IMPORTANT

Failure to follow the Considerations and precautions can cause serious injury / damage and will render all warranty given by Sleipner Motor AS VOID.

Never use thrusters when close to objects/ persons or pets in the water. The thruster will draw objects into the tunnel and the rotating propellers. This will cause serious injuries and damage the thruster.

Always turn the main power switch off before touching any part of the thruster, An incidental start while touching moving parts can cause serious injuries.

Never store items (e.g. equipment, sails, ropes etc.) in the same compartment as the thruster. When the thruster runs for an extended period, it can reach 150°C and will cause damage to nearby items or cause a fire.

Any loose items near the thruster motor can cause problems with electrical wiring coming loose and short-circuiting.

- Ensure you know the location of the main battery switch that disconnects the thruster from all power sources (batteries) so the thruster can be turned off in case of serious malfunction.
- Always turn the control device off when the thruster is not in use or when leaving the boat.
- When leaving the boat always turn off the main power switch for the thruster.
- Never use thrusters out of water.
- If the thruster stops giving thrust while running, there is possibly a problem in the drive system. You must immediately stop running the thruster and turn it off. Running the thruster for more than a few seconds without resistance from the propeller can cause serious damage to the thruster.
- We advise keeping the main engine(s) running while using the thruster. This will keep the batteries in a good charge condition. It will also give better performance to the thruster.
- If the performance of the thruster is reduced check the battery system or check the tunnel for marine growth.
- If two panels are operated with conflicting directions at the same time the thruster will not run. If both are operated in the same direction, the thruster will run in this direction.
- If you notice any faults with the thruster switch it off to avoid further damage.
- The electro motor, its components, contacts/ plugs or other joints in the control cables must be mounted so they will remain dry at all times.
- It is the owner/ captain/ other responsible parties full responsibility to assess the risk of any unexpected incidents on the vessel. If the thruster stops giving thrust for some reason while manoeuvring you must have considered a plan on how to avoid damage to persons or other objects.
- The primary purpose of the thruster is to manoeuvre/ dock the vessel. Forward/ reverse speed must not exceed 4 knots when operated.

! Please refer to the graphic for special considerations relating to your model !

Take time to practice operation in open water to become familiar with the thruster and to avoid damages to your boat or people.

How to use the Thruster

1. Turn on the main power switch for the thruster. **(NB: Always turn off the main power switch when not on-board.)**
2. Turn on the control panel by pushing both "ON" buttons on the Sleipner panel simultaneously.
* Turn off the control panel by pushing both "OFF" button

(NB: Control panels designed for the hydraulic system have a replace the secondary 'OFF' button with a red 'STOP' button for an emergency stop function.)

Joystick Control

To Turn the bow in the desired direction move the joystick in the direction you wish the bow to move.

Button Control

For 'HOLD' function.

* For other controls like foot switches or toggle-switches please refer to that products user manual for detailed operational use.

How to use a combined bow and stern thruster

The combination of a bow and stern thruster offers total manoeuvrability to the boat and the ability to move the bow and the stern separately from each other. This enables you to move the boat sideways in both directions and turn the boat around its axis 360° staying stationary.

(NB: At speed the side thruster will have little or no effect to steer the vessel.)

Proportional control thruster

For proportional control move the joystick equivalent to the amount of thrust you intend to receive.

PRO proportional CONTROL PANEL



PJC211

PJC212

S-Link REMOTE CONTROL



RCS-20

Proportional Control Panel

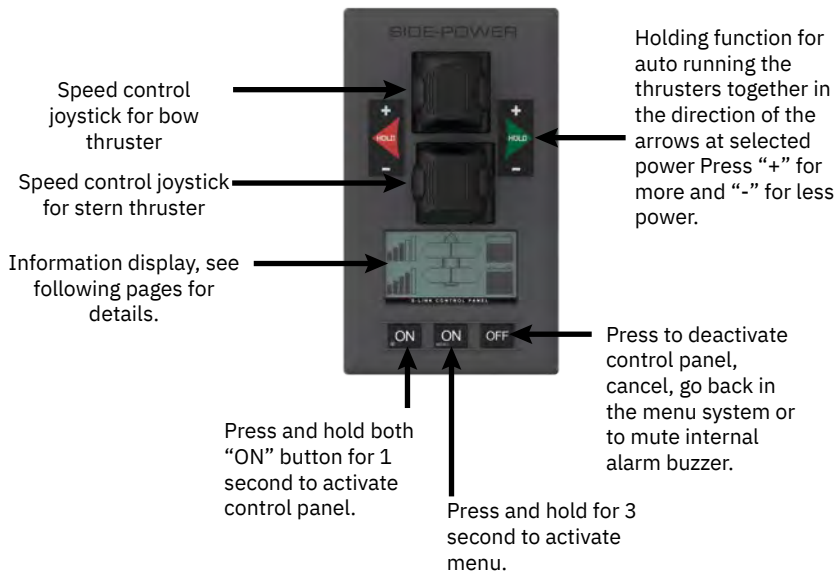

Activating the bow thruster



*Control panel example



Activating the stern thruster



*Control panel example



Activating both bow and stern thruster to push the boat sideways

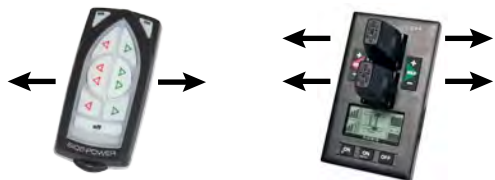

*Control panel example

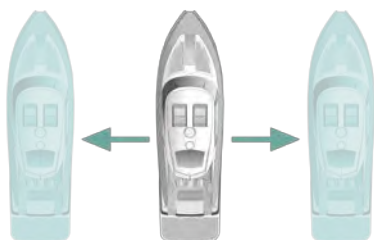

Activating both bow and stern thruster to rotate the boat on axis



*Control panel example

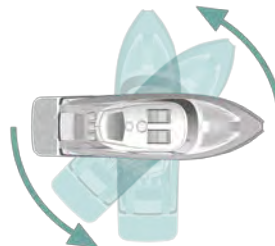

! Please refer to the graphic for special considerations relating to your model !

As a part of the seasonal service of your Thruster before every season, always check that:

In Water

- The area around the thruster inside the boat is clean and dry. Ensure there are no signs of water leaks.
- All electrical connections are clean and fastened firmly.
- Ensure that your batteries are in good condition.

Out of Water

- Check the propeller(s) or tunnel for any damage for example impact damage.
- The propeller(s) is fastened securely to the gear leg.
- Check all components of thruster are fastened securely.
- Clean the tunnel and gear leg from marine growth.
- Paint the propeller and gear leg with anti-fouling before every season to keep it clean from sea growth. **(NB: Never paint the anode, sealing or propeller shaft. Ensure paint does not enter the space between the propeller and the gear leg.)**
- Change the anode before every season, or when half the anode has eroded. Always use a sealant or thread glue on the holding screw to ensure that it does not fall off.
- If your product uses an external oil tank, ensure the oil level remains the same.
- If there is a problem with your Ignition Protected stern thruster, please contact your dealer.

The variable frequency drive, delivered as part of the SAC thruster kit, is preconfigured and tuned for the specific thruster and motor. No additional setup is required after installation.

Maintenance

See own manual for VFD

IMPORTANT

VFD comes pre-configured from the manufacturer. DO NOT personally reconfigure any settings on the VFD.

AC
*240
*320
*360

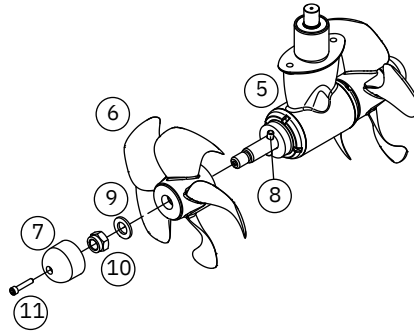

AC
*450
*520

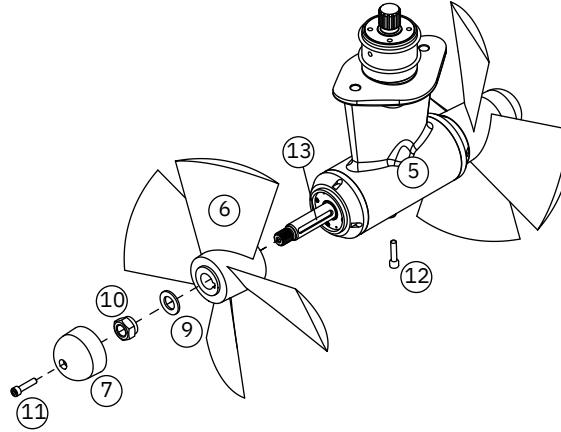
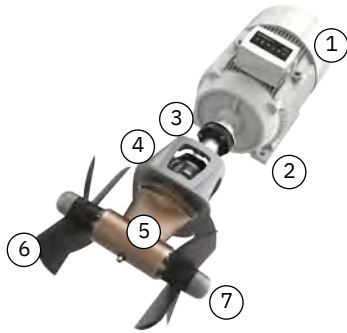

AC
*400

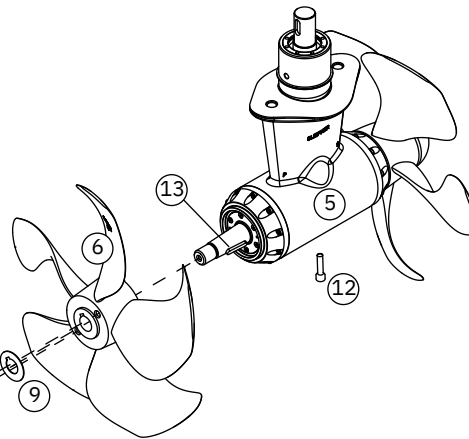
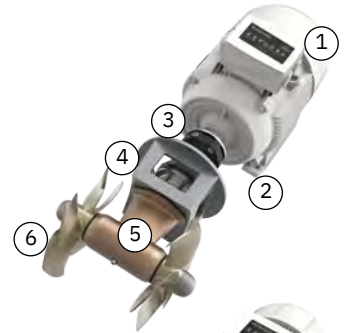

AC
*700
*750
*900
*1100
*1300
*1400

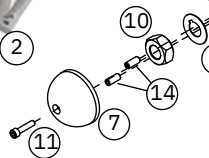
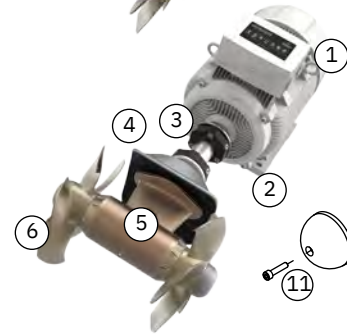

KEY:

- 1. Motor
- 2. Mounting feet
- 3. Cardan shaft with flexible coupling
- 4. Bracket for gear leg support
- 5. Gear Leg
- 6. Propeller
- 7. Anode
- 8. Drive pin
- 9. Washer
- 10. Lock Nut
- 11. Fastening Screw for anode
- 12. Oil drain screw with washer

Before seeking assistance from the website help desk from your Side-Power dealer/ distributor, please perform these tests.

(NB: If you are unable to understand what to check, you must consult a Side Power distributor.)

CHECK	SOLUTION
The motor runs, but there is no thrust	
Check propellers are fitted, fastened correctly and not damaged on the prop shaft.	Re-fasten or replace if necessary
* Check the flexible coupling between the motor and drive shaft is fitted correctly and not damaged.	Replace if necessary
* Check the gear box is not damaged.	Replace if necessary
The thrusters performance is reduced	
Check the propeller, gear house and tunnel are free from growth/ barnacles or debris and damage.	If there is growth in the tunnel, this will disturb/ block the water flow and significantly reduce performance
Check the battery is in a good working condition.	(NB: Keep the main engine(s) running in use to have a continuous charge to the batteries) <ul style="list-style-type: none"> • Check batteries are not worn out or in a bad charged condition • Check electrical connections/ wiring for damage or wear (corrosion) • Check cables are the correct size per the product manual • Tighten/ re-adjust connections
The thruster does not start/ works in only one direction or does not turn off	
Check the main switch is active/ on.	Switch the main switch open if it is closed.
Check all battery fuses are in good condition.	<ul style="list-style-type: none"> • Check batteries • Check electrical connections/ wiring for damage or wear (corrosion) • Tighten/ re-adjust and clean connections
The thruster is not shutting off after the Joy Stick/ panel is disengaged.	Hit the main switch to disengage the thruster. Contact and consult a Side Power distributor as the control system has been damaged.
The thruster works in only one direction	
Damaged relay.	Hit the main switch to disengage the thruster. Contact and consult a Side Power distributor as the control system has been damaged.
The thruster runs in a pulsing action	
This is a build-in error response. -Solenoids failure	Hit the main switch to disengage the thruster. Contact and consult a Side Power distributor.
The solenoid might be in a lock-in/ auto stop position.	Hit the main switch to disengage the thruster. Contact and consult a Side Power distributor.

* Not applicable to SX thrusters.

Before seeking assistance from the website help desk from your Sleipner dealer/ distributor, please perform these tests.

(NB: If you are unable to understand what to check, you must consult a Sleipner distributor.)

Control panels operating on the S-link system display all faults via the control panel interface or via other warning methods.

To review any issues of your product refer to the appropriate user manual for a complete list of fault codes and troubleshooting guides.

For additional supporting documentation, we advise you to visit our website www.sleipnergrouper.com for the spare parts list.

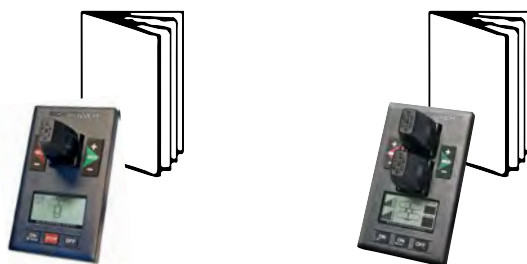

Find your local professional dealer from our certified worldwide network for expert service and support.

visit our website www.sleipnergrou.com/support

For additional supporting documentation, we advise you to visit our website www.sleipnergrou.com and find your Sleipner product.

1. Sleipner Motor AS (The "Warrantor") warrants that the equipment (parts, materials and embedded software of products) manufactured by the Warrantor is free from defects in workmanship and materials for the purpose for which the equipment is intended and under normal use and service (the "Warranty").
2. This Warranty is in effect for two years (Leisure Use) or one year (Commercial and other Non-leisure Use) from the date of purchase by the end user (for demonstration vessels, the dealer is deemed as end user).
3. This Warranty is transferable and covers the equipment for the specified warranty period.
4. The warranty does not apply to defects or damages caused by faulty installation or hook-up, abuse or misuse of the equipment including exposure to excessive heat, salt or fresh water spray, or water immersion except for equipment specifically designed as waterproof.
5. In case the equipment seems to be defective, the warranty holder (the "Claimant") must do the following to make a claim:
 - (a) Contact the dealer or service centre where the equipment was purchased and make the claim. Alternatively, the Claimant can make the claim to a dealer or service centre found at www.sleipnergrou.com. The Claimant must present a detailed written statement of the nature and circumstances of the defect, to the best of the Claimant's knowledge, including product identification and serial nbr., the date and place of purchase and the name and address of the installer. Proof of purchase date should be included with the claim, to verify that the warranty period has not expired;
 - (b) Make the equipment available for troubleshooting and repair, with direct and workable access, including dismantling of furnishings or similar, if any, either at the premises of the Warrantor or an authorised service representative approved by the Warrantor. Equipment can only be returned to the Warrantor or an authorised service representative for repair following a pre-approval by the Warrantor's Help Desk and if so, with the Return Authorisation Number visible postage/shipping prepaid and at the expense of the Claimant.
6. Examination and handling of the warranty claim:
 - (a) If upon the Warrantor's or authorised service Representative's examination, the defect is determined to result from defective material or workmanship in the warranty period, the equipment will be repaired or replaced at the Warrantor's option without charge, and returned to the Purchaser at the Warrantor's expense. If, on the other hand, the claim is determined to result from circumstances such as described in section 4 above or a result of wear and tear exceeding that for which the equipment is intended (e.g. commercial use of equipment intended for leisure use), the costs for the troubleshooting and repair shall be borne by the Claimant;
 - (b) No refund of the purchase price will be granted to the Claimant, unless the Warrantor is unable to remedy the defect after having a reasonable number of opportunities to do so. In the event that attempts to remedy the defect have failed, the Claimant may claim a refund of the purchase price, provided that the Claimant submits a statement in writing from a professional boating equipment supplier that the installation instructions of the Installation and Operation Manual have been complied with and that the defect remains.
7. Warranty service shall be performed only by the Warrantor, or an authorised service representative, and any attempt to remedy the defect by anyone else shall render this warranty void.
8. No other warranty is given beyond those described above, implied or otherwise, including any implied warranty of merchantability, fitness for a particular purpose other than the purpose for which the equipment is intended, and any other obligations on the part of the Warrantor or its employees and representatives.
9. There shall be no responsibility or liability whatsoever on the part of the Warrantor or its employees and representatives based on this Warranty for injury to any person or persons, or damage to property, loss of income or profit, or any other incidental, consequential or resulting damage or cost claimed to have been incurred through the use or sale of the equipment, including any possible failure or malfunction of the equipment or damages arising from collision with other vessels or objects.
10. This warranty gives you specific legal rights, and you may also have other rights which vary from country to country.

At Sleipner we continually invest to develop and offer the latest technology in marine advancements. To see the many unique designs we have patented visit our website www.sleipnergrou.com/patents

© Copyright Sleipner Motor AS, 2021

The information given in the document was correct at the time it was published.

However, Sleipner Motor AS can not accept liability for any inaccuracies or omissions it may contain. Continuous product improvement may change the product specifications without notice.

Therefore, Sleipner Motor AS can not accept liability for any possible differences between product and document.

Register your product and learn more at www.sleipnergroun.com



SLEIPNER AS

P.O. Box 519

N-1612 Fredrikstad

Norway

www.sleipnergroun.com

Made in Norway

