

Picture shows 6527-S actuator with cable (not included in standard unit)

Model 6527-S Electronic Actuator

Being a modified version of the regular 6527 actuator, the 6527-S actuator is used exclusively in the Kobelt Mighty Mariner System to operate and position lever-actuated mechanisms. Using the latest technology in propulsion control, this actuator unit forms the heart of the Mighty Mariner Control System. The actuator monitors all input information from the control heads and their associated switch panels, its lever position as well as the synchronizer input. This actuator also controls and positions its Throttle and Clutch levers and communicates with the control stations through panel lights and sonalerts. The 6527-S electronic actuators are constructed in bronze and stainless steel, except for the motor and worm. This unit has a high torque of 180 in-lbs.

The basic unit on Model 6527-S comes with manual override and one trim pot per side for stroke adjustment. The actuator does not have an internal resilient link. Hence the stroke must be precisely adjusted to suit the device being controlled.

Note: This actuator is not waterproof and therefore should not be immersed in liquid or washed.

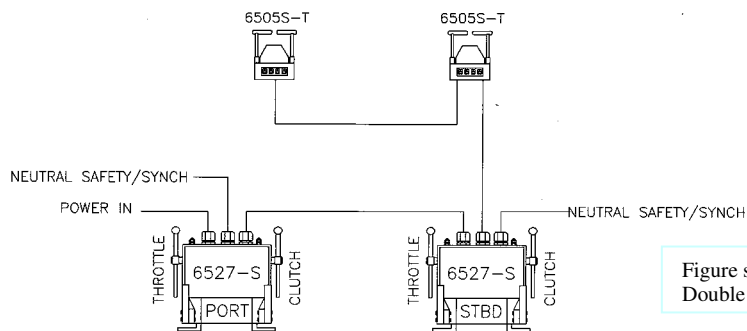
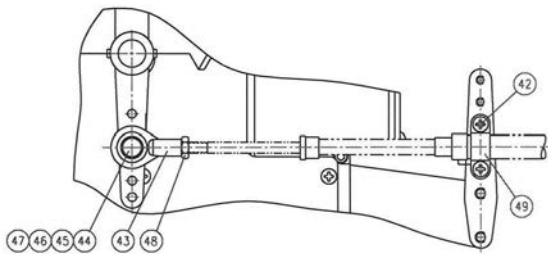
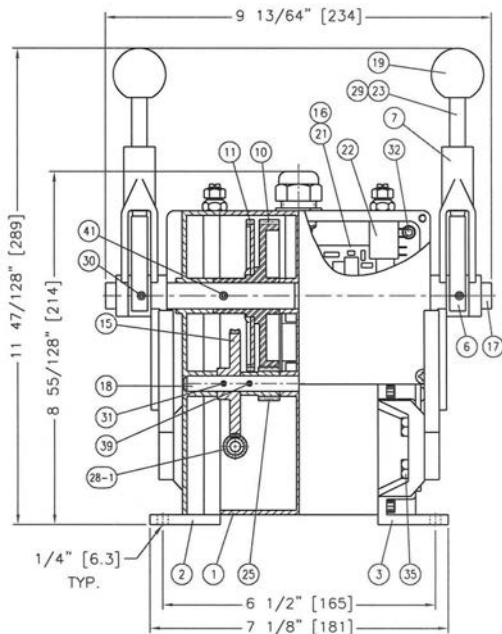
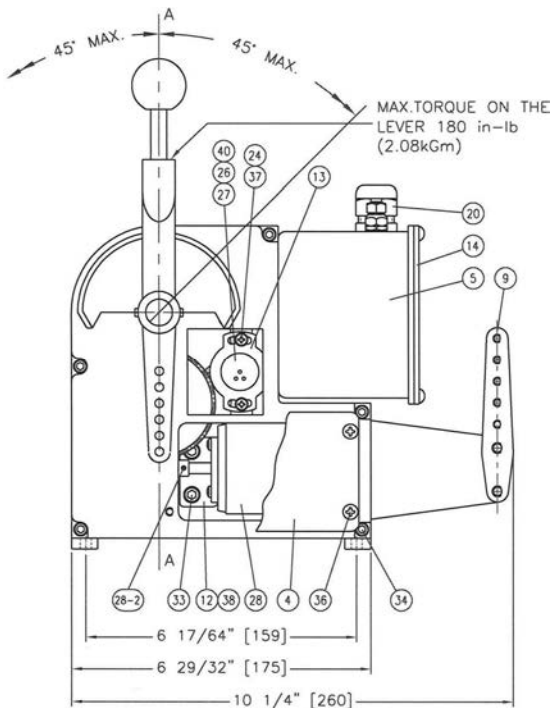

Figure shows typical configuration for Double station Twin engine system

MODEL 6527-S



Item	Qty	Part Number	Description
1	1	6527-0001	Centre Housing
2	1	6527-0002	Side Housing
3	1	6527-0003	Side Housing
4	2	6527-0004	Cover
5	1	6527-0005	Connection Housing
6	2	6527-0006	Disconnect Cam
7	2	6527-0007	Disconnect Arm
9	2	6527-0009	Stationary Arm
10	2	6527-0010	Spur Gear
11	2	6527-0011	Feedback Gear
12	2	6527-0012	Motor Bracket, right
13	1	6527-0013L	Potentiometer Bracket - left
13	1	6527-0013R	Potentiometer Bracket - right
14	1	6527-0014	Cover
15	2	6527-0015	Worm Pinion
16	1	6527-1002	Heat Sink
17	1	6527-0017	Shaft - Long
18	2	6527-0018	Shaft
19	2	2030-0001	Knob Black
20	3	6001-0249	Connecting Gland
21	2	6527-1001	Circuit Board
22	2	6002-4000	Trim Pot - 1K
23	2	6524-0015	Handle
24	2	1023-0106	Flat Washer
25	2	6524-0021	Pinion
26*	2	6524-0022	Potentiometer Drive Gear
27	2	POT-6	Potentiometer - 5K
28	2	Motor-14201	Motor Pittman 24VDC, "14201E175-R1"
28-1	2	6524-0019	Worm
28-2	2	1024-0406	Spring Pin
29*	1*	1201-0140	Spring
30*	2	1024-0818	Spring Pin
31	2	1024-0512	Spring Pin
32	4	1002-0806	Socket Hd Cap Screw
33	4	1002-1008	Socket Hd Cap Screw
34	10	1002-0808	Socket Hd Cap Screw
35	4	1001-1012	Hex Hd Machine Screw
36	22	1010-0806	Round Hd Philips Screw
37	20	1012-0606	Pan Hd Philips Screw
38*	1	6527-0012A	Motor Bracket, left
39	2	1024-0509	Spring Pin
40	2	1016-0602	Set Screw
41	2	1024-0814	Spring Pin
Cable Clamp Kit			
42	4	1010-0810	Round Hd Screw
43	2	2144/3	Rod End
44	2	1001-0814	Hex Bolt
45	2	1023-0108	Flat Washer
46*	2	1023-0308	Lock Washer
47*	2	1022-0108	Hex Nut
48	2	1022-0260	Jam Nut
49	2	2108-0002	Cable Clamp, 40 series

All dimensions in inches (mm)

* Item not shown on drawing

MODEL 6527-S

